



US009335132B1

(12) **United States Patent**
Collier

(10) **Patent No.:** **US 9,335,132 B1**
(45) **Date of Patent:** ***May 10, 2016**

(54) **SWEPT HEMISPHERICAL PROFILE
AXISYMMETRIC CIRCULAR LINEAR
SHAPED CHARGE**

(71) Applicant: **Innovative Defense, LLC**, Smithville,
TX (US)

(72) Inventor: **Nicholas Collier**, Smithville, TX (US)

(73) Assignee: **Innovative Defense, LLC**, Smithville,
TX (US)

(*) Notice: Subject to any disclaimer, the term of this
patent is extended or adjusted under 35
U.S.C. 154(b) by 223 days.

This patent is subject to a terminal dis-
claimer.

2,804,823 A	9/1957	Jablansky
3,302,567 A	2/1967	Venghiattis
3,561,361 A	2/1971	Kessenich et al.
3,721,192 A	3/1973	McEwan et al.
3,838,644 A	10/1974	Prochnow et al.
3,903,803 A	9/1975	Losey
3,908,933 A	9/1975	Goss et al.
4,300,453 A	11/1981	Bigler
4,313,380 A	2/1982	Martner et al.
4,342,262 A	8/1982	Romer et al.
4,425,850 A	1/1984	Grossler
4,430,939 A	2/1984	Harrold
4,441,428 A	4/1984	Wilson
4,450,768 A	5/1984	Bell
4,551,287 A	11/1985	Bethmann
4,632,036 A	12/1986	Ringel
4,643,097 A	2/1987	Chawla et al.
4,665,826 A	5/1987	Marer
4,669,386 A	6/1987	Precoul et al.
4,672,896 A	6/1987	Precoul et al.

(Continued)

(21) Appl. No.: **14/181,282**

(22) Filed: **Feb. 14, 2014**

Related U.S. Application Data

(60) Provisional application No. 61/765,656, filed on Feb.
15, 2013.

(51) **Int. Cl.**
F42B 1/00 (2006.01)
F42B 1/028 (2006.01)

(52) **U.S. Cl.**
CPC **F42B 1/028** (2013.01)

(58) **Field of Classification Search**
USPC 102/307, 318; 175/2; 166/55.2
See application file for complete search history.

(56) **References Cited**

U.S. PATENT DOCUMENTS

2,757,611 A	8/1956	Church et al.
2,796,833 A	6/1957	Sweetman

FOREIGN PATENT DOCUMENTS

GB 2246621 5/1992

Primary Examiner — J. Woodrow Eldred

(74) *Attorney, Agent, or Firm* — Hemingway & Hansen,
LLP; D. Scott Hemingway

(57) **ABSTRACT**

In the hemispherical family of axisymmetric circular linear shaped charge liners, this novel swept hemispherical profile shaped explosive device produces a stable jet with the ability to aim the jet by moving the initial explosive impulse ring on the liner surface inward or outward from the pole of the liner profile. The precision of the circular simultaneous initiation of the HE billet is accomplished by the use of a novel Circular Precision Initiation Coupler (CPIC). This CPIC uses a single point initiation to create a simultaneous peripheral detonation of the HE billet that collapses and drives the swept liner into a high speed stretching hollow cylindrical projectile, or more commonly called a jet in the industry.

25 Claims, 1 Drawing Sheet

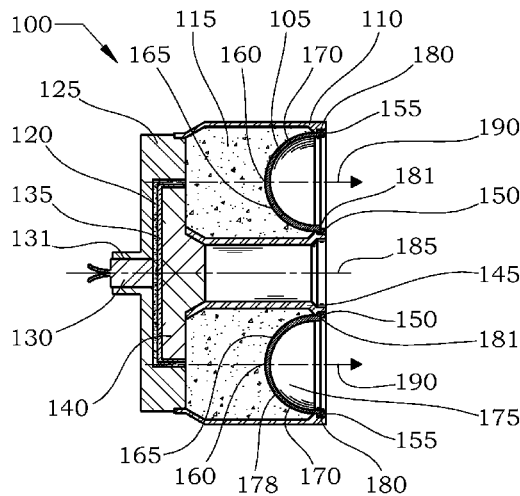

(56)

References Cited

U.S. PATENT DOCUMENTS

4,688,486	A	8/1987	Hall et al.		6,179,944	B1	1/2001	Monolo et al.
4,759,886	A	7/1988	Daugherity		6,354,219	B1	3/2002	Pratt et al.
4,833,994	A	5/1989	Strobush		6,443,068	B1	9/2002	Meister
4,841,864	A	6/1989	Grace		6,477,959	B1	11/2002	Ritman et al.
4,896,609	A	1/1990	Betts et al.		6,644,205	B2	11/2003	Ritman et al.
4,982,665	A	1/1991	Sewell et al.		6,668,726	B2	12/2003	Lussier
4,989,517	A	2/1991	Adimari et al.		6,758,143	B2	7/2004	Ritman et al.
5,003,884	A	4/1991	Nissl et al.		6,792,866	B2	9/2004	Grattan
5,078,069	A	1/1992	August et al.		6,840,178	B2	1/2005	Collins et al.
5,088,416	A	2/1992	Sabranski		7,261,036	B2	8/2007	Bourne et al.
5,235,128	A	8/1993	Hardesty et al.		7,621,221	B2	11/2009	Ritman
5,245,927	A	9/1993	Ranes		7,753,850	B2	7/2010	Averkiou et al.
5,251,561	A	10/1993	Murphy		7,779,760	B2	8/2010	Konig
5,269,223	A	12/1993	Mattsson et al.		7,810,431	B2	10/2010	Heine et al.
5,279,228	A *	1/1994	Ayer	F42B 1/032 102/306	7,819,064	B2	10/2010	Saenger et al.
					8,375,859	B2	2/2013	Sagebiel
5,320,044	A	6/1994	Walters		2003/0183113	A1	10/2003	Barlow et al.
5,522,319	A *	6/1996	Haselman, Jr.	F42B 1/028 102/306	2005/0188878	A1	9/2005	Baker et al.
					2006/0107862	A1	5/2006	Davis et al.
5,621,185	A	4/1997	Spengler et al.		2008/0011179	A1	1/2008	Michel et al.
5,753,850	A	5/1998	Chawla et al.		2008/0134925	A1	6/2008	Konig
5,847,312	A	12/1998	Walters et al.		2008/0289529	A1	11/2008	Schilling
5,988,071	A	11/1999	Taylor		2009/0211481	A1	8/2009	Schwantes et al.
					2011/0232519	A1	9/2011	Sagebiel
					2013/0199394	A1	8/2013	Collier

* cited by examiner

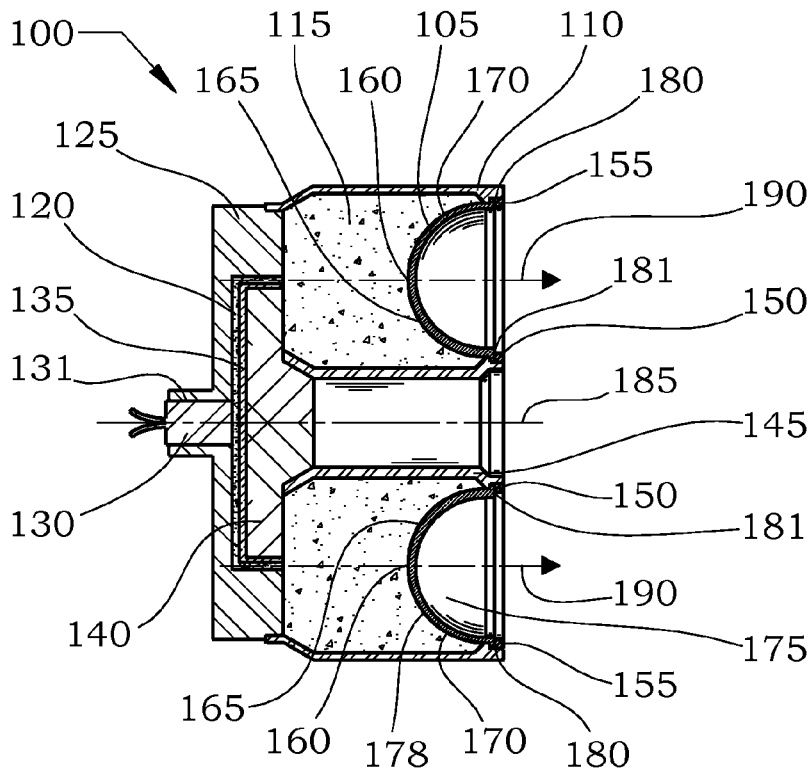

FIG. 1

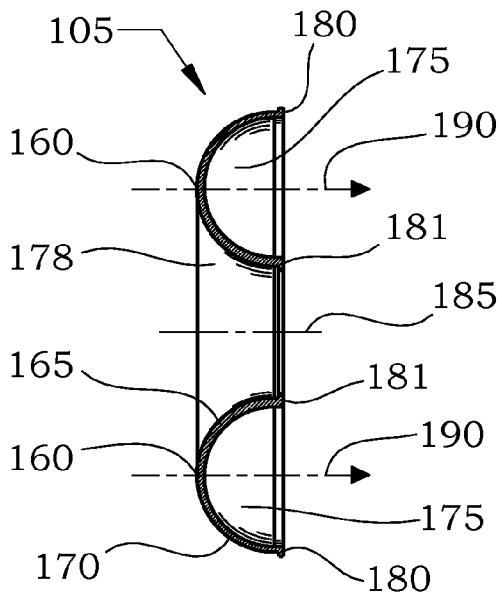

FIG. 1A

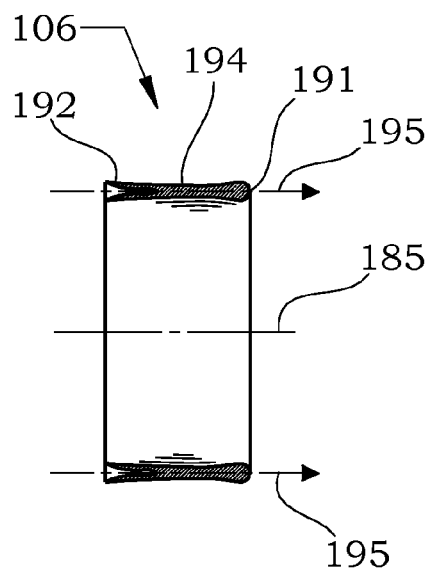

FIG. 1B

1

SWEEP HEMISPHERICAL PROFILE AXISYMMETRIC CIRCULAR LINEAR SHAPED CHARGE

RELATED APPLICATION DATA

This application is a non-provisional application which claims the benefit of U.S. Provisional Application No. 61/765,656, filed Feb. 15, 2013.

TECHNICAL FIELD OF INVENTION

This invention relates to shaped charges and in particular to a swept hemispherical profile shaped explosive device that produces a full caliber or greater hole, that is to say a hole as large as the explosive charge diameter (CD).

BACKGROUND OF THE INVENTION

Shaped charges come in many sizes and shapes and are used mainly for military weaponry and oil well perforating; to a lesser extent demolition and rescue are also users of this complex technology.

The concept of shaping an explosive charge, in order to focus its energy was known in 1792. ("The History of Shaped Charges" Donald R Kennedy)

In 1884 Max von Foerster conducted experiments in Germany showing that a hollow cavity explosive charge will focus the explosive energy and produce a collimated jet of high speed gasses along the longitudinal axis of the cavity, this jet also could penetrate steel.

In 1888, while conducting research for the U.S Navy, at Newport R.I., Charles Munroe discovered that not only could explosive energy be focused, but lining the hollow cavity in the explosive with metal increased the penetration dramatically, the effect is commonly called the Munroe effect.

These discoveries were further studied in 1910 by Egon Neumann of Germany who conducted similar experiment's, which showed that a cylinder of explosive with a metal lined conical hollow cavity could penetrate through steel plates. The military implications of this phenomenon were not realized until the lead up to world war two.

In the 1930's flash x-ray technology was developed which allowed the in depth study of the Shaped Charge jetting process. With this new and other diagnostics, it was possible to take XRay pictures of the collapse of the liner and the resulting jet. This led to a more scientific and complete understanding of the Munroe principle and emphasized the power of shaped charges.

Modern shaped charges as used in anti-tank weapons produce a long stretching rod like metal jet that penetrates about 5 to 8 charge diameters in steel, deeper in masonry or rock. The average diameter of a 5 CD through hole in steel from these charges is less than 15% of the explosive charge diameter (CD) of the device. The holes made by these jets do not provide sufficient diameter to allow follow on or follow through devices to pass into the perforation and add to the hole depth.

There have been some specialized efforts by Haliburton to produce other than conical type shaped charges for special purposes such as pipe cutting and anchor chain cutting. These types of charges are called linear shaped charges and use the two dimensional collapse to produce a thin sheet like jet with somewhat similar cutting power to the usual conical shaped charge. These linear shaped charges are flexible and can be formed by hand into desired shapes. The British Wall AXE circa 1960 is an example of a formable linear shape charge

2

with a wide angle liner; the device is used against light structures such as wooden doors and thin walls and do not give very deep penetration.

Throughout the history of shaped charges the primary effort of research in this field was directed toward depth of penetration by the jet. Although hole size was considered in the past, little research has been done on significantly increasing jet diameter and cross-sectional shape of the jet to produce a larger hole diameter. In oil field applications a larger hole is most desirable as the flow area of the hole increases rapidly with an increase in hole diameter. With the ability to produce a full caliber hole, a follow on or follow through device can be deployed into the hole to the correct standoff from the bottom of the hole. When detonated at the correct standoff this will increase the hole depth by that of the primary hole producing device, this can be repeated numerous times in the same hole.

In the case of oil well stimulation the ability to place lined shaped charges into the formation outside of a casing, not only increases hole depth but blast affects from the HE fractures the local rock increasing its permeability and flow rate. Many other industries can benefit from this innovation from Military to Mining so the motivation to pursue the concept of producing a full caliber hole with a shaped charge is to provide new means to these industries.

SUMMARY OF INVENTION

The swept profile designs of the swept hemispherical profile axisymmetric circular linear shaped charge (ACLSC) will efficiently remove more target material than a rod producing shaped charge. This increase in efficiency is achieved by making a much larger diameter jet. To produce a significantly larger jet one must consider focusing the energy of the jetting liner in a much larger pattern than that of a conventional shaped charge. This large diameter jet is achieved by detonating the high explosive (HE) billet, which is a mass of high explosive, thereby forming the liner into a stretching hollow cylindrical jet. This jet being close to the same diameter as the device forms a hole larger than the device diameter and removes the full device diameter of the target material.

The swept hemispherical profile (SHP) liner family will produce a slower but more massive jet when compared to a swept conical design, but the SHP liner forms a stable jet with the ability to aim the jet by moving the initial explosive impulse ring on the liner surface inward or outward from the pole of the liner profile.

The precision of the circular simultaneous initiation of the HE billet is accomplished by the use of a novel Circular Precision Initiation Coupler (CPIC). The CPIC initiation system is a single point to ring or peripheral initiation and is mated to the aft end of the HE billet and centered by the outer body so as to align the CPIC output with the pole axis of the liner. As the detonation wave reaches the intersection of the collapse axis and pole of the liner the enormous detonation pressures cause the pole material of the liner to accelerate forward and the inner and outer walls to elongate along the collapse axis forming the walls of the stretching hollow cylindrical projectile, or more commonly called a jet in the industry.

BRIEF DESCRIPTION OF THE DRAWINGS

Because of the complexity of shapes involved, the inventor will use descriptive drawings and text to describe the device and how it functions.

FIG. 1 is a cross-sectional view of a swept hemispherical shaped charge device (SHSC).

FIG. 1A is a cross-sectional view of a swept hemispherical profile (SHP) liner.

FIG. 1B is a cross-sectional view of a hollow circular jet formed from a SHSC.

DETAILED DESCRIPTION

The swept profile designs of the swept hemispherical profile axisymmetric circular linear shaped charge (ACLSC) will efficiently remove more target material than a rod producing shaped charge. This increase in efficiency is achieved by making a much larger diameter jet. To produce a significantly larger jet one must consider focusing the energy of the jetting liner in a much larger pattern than that of a conventional shaped charge. This large diameter jet is achieved by detonating the high explosive (HE) billet, which is a mass of high explosive, thereby forming the swept liner profile into a stretching hollow cylindrical jet. This jet being close to the same diameter as the device forms a hole larger than the device diameter and removes the full device diameter of the target material.

Although the ACLSC charge will not penetrate as deep as a conventional shaped charge it will remove a full charge diameter of material, which allows the SHP to remove far more material volume than a much deeper penetrating conventional shaped charge device.

Since ACLSC devices produce, full caliber holes it is possible to send follow on charges into the penetration deepening the hole and sending the debris out of the hole at high velocity. Follow on charges are not possible with traditional shaped charges since the penetration hole is very much smaller than the charge diameter which prevents the next charge from obtaining the correct standoff from the bottom of the hole. Oil and gas well completions and military users will benefit greatly from the use of ACLSC devices which is the goal of this shaped charge concept and development.

This novel swept hemispherical profile axisymmetric circular linear shaped charge (ACLSC) differs from a conventional lined shaped charge device, in that the ACLSC produces a large diameter hollow cylindrical jet as opposed to a rod like jet from a conventional lined shaped charge. This large diameter hollow jet will produce a full caliber or greater sized hole. This full caliber hole capability allows for a follow on or follow through devices of equivalent diameter to be placed at the correct standoff, in the hole produced by first said device. The ability to place secondary and tertiary devices in said hole allows the hole to be increased in depth with each device detonation in an infinite target. The uses and advantages of this innovation in shaped charge design are many in both military and commercial applications.

The ACLSC device produces a parallel, converging, or diverging jet relative to the axis of symmetry, and is capable of removing the full diameter of material without leaving a center plug of target material to a semi-infinite depth by the repeated use of follow on devices.

The liner profile names, represent the two dimensional (2D) profile that would be seen if a hollow hemisphere were cut sagittal along the longitudinal axis of the hemisphere creating a hollow half hemisphere. This hollow half hemisphere profile is swept about the central axis of symmetry of the device leaving a through hole in the center providing for a central body that serves as inner high explosive (HE) containment, expansion path for detonation gasses, space for shock absorption materials, and can also contain a central projectile producing device.

To simplify the description of the geometry, detonation and collapse of a SHP liner we could look only at 2D profile of the

swept liner shape and other device components as if the charge was cut sagittal through the axis of symmetry. This cut will show the liner profile that makes the hollow toroid with an inner and outer wall joined at the pole or collapse axis of the curvature. The collapse axis that passes through the apex of swept liner is visually an axis when viewing it in a 2D profile, but in reality it is not a true axis. If viewed in three dimensional (3D) space, this collapse axis would be seen as a hollow cylinder with a diameter equal to the pole diameter of the liner extending through the length of the device and coaxial to the device axis of symmetry. For ease of discussion, the 2D term collapse axis will be used to describe the 3D hollow cylinder that the liner collapses on.

The swept profile of a hollow hemisphere, cut through the pole by a plane, as seen from an equatorial view, is revolved or swept about a central axis of symmetry. This sweeping or revolving of the profile forms a hollow half torus or circular trough liner with a semicircular cross section. This liner has an outer diameter and an inner diameter and a pole axis or collapse axis at the pole of the hemispherical profile and parallel to the axis of symmetry. The description above would designate a hole in the center formed by the inner wall of the circular liner.

It is not intended to imply that round or circular configuration is the only form this peripheral lined shaped charge can have. The HE initiation simultaneity, from a single point to a periphery for other shapes such as ellipsoids, square, rectangle even a closed spline configuration is much more complex than the round form.

The swept hemispherical profile (SHP) liner family will produce a slower but more massive jet when compared to a swept conical design, but the SHP liner forms a stable jet with the ability to aim the jet by moving the initial explosive impulse ring on the liner surface inward or outward from the pole of the liner profile. In one of a number of preferred configurations this novel swept profile shaped explosive device produces a stretching hollow cylindrical jet. The aforementioned jet is formed by the pressures created by the detonation of the high explosive (HE) billet in a circular pattern at the aft end of the billet and aligned with pole axis of the swept liner profile.

The capability of the SHP liner device to produce a super caliber hole allows follow on devices of the same caliber to theoretically produce the hole to infinite depths. This novel axisymmetric SHP shaped explosive device differs from a conventional lined shaped charge in that the SHP liner device produces a large diameter hollow cylindrical jet as opposed to a rod like jet from a conventional lined shaped charge. The uses and advantages of this innovation in shaped charge design are many in both military and commercial applications.

This ACLSC device consists of a swept hemispherical profile (SHP) liner, a HE billet, an outer body, an inner body, an initiation system and shock attenuation components. Commercial or Military versions of this device could be tailored to the task or demand from the industry. The ACLSC is interfaced to an appropriately shaped quantity of high explosive (HE), having provisions for a precision initiation train, HE containment, and tamping of HE if desired.

The swept hemispherical profile (SHP) liner for this application looks like a length of thin walled tubing formed into a circle and cut across the equatorial diameter like a hollow half torus with a through hole formed by the inner wall diameter. The liner also has a polar axis and a through hole at its center. This through hole provides for the inner body and shock attenuation materials and is about one third the diameter of the liner's outer mounting diameter. The SHP liner could be

described as a hollow half torus, though hollow half toroid's can have any contour or profile.

Preferably the SHP liner uses a copper material, but liners may be made from most any metal, ceramic, powdered metals, tungsten, silver, copper or combination of many materials. The intent here is to develop the concept of this circular linear swept profile shaped charge not the liner material.

The HE Billet in its most basic form is a right circular cylinder having a through hole at its center leaving a wall thickness greater than the annulus width (AW) between the inside and outside diameters of the liner. The billet is of sufficient length to provide adequate head height of HE above the liner surface so there is sufficient HE to drive the liner in the desired fashion. The wall of the HE billet has a concentric swept concavity at its front end matching the outside convex surface of the liner, in size and contour. The wall thickness of the HE being larger than the annulus width provides for super caliber explosive all the way to the equator of the half torus or circular hollow trough. This makes for higher jet velocities, more jet mass, longer jet and better penetration performance. The liner is inserted snugly into the concavity of the HE billet, making a liner HE sub assembly of the device. The SHP liner device can use cast, pressed, extruded or even hand packed HE from any high quality explosive.

The swept profile liner configurations included in this embodiment are: Hemispherical with constant liner wall thickness (SHPCW), and Hemispherical with varying liner wall thickness (SHPVW), in relation to the inside and outside surfaces of the liner trough or half torus shell.

To initiate a swept profile shaped charge the HE billet detonation should be initiated by a simultaneous ring detonation from a Circular Precision Initiation Coupler (CPIC). The CPIC initiates detonation of the HE billet in a circular pattern at the aft end of the HE billet and at the exact diameter of the pole of the swept liner profile. The precision of the circular simultaneous initiation of the HE billet is accomplished by the use of a novel Circular Precision Initiation Coupler (CPIC). The CPIC initiation system is a single point to ring or peripheral initiation and is mated to the aft end of the HE billet and centered by the outer body so as to align the CPIC output with the pole axis of the liner. As the detonation wave reaches the intersection of the collapse axis and pole of the liner the enormous detonation pressures cause the pole material of the liner to accelerate forward and the inner and outer walls to elongate along the collapse axis forming the walls of the stretching hollow cylindrical jet. This CPIC uses a single point initiation to create a simultaneous peripheral detonation of the HE billet that collapses and drives the SHP liner into a high speed stretching hollow cylindrical projectile, or more commonly called a jet in the industry. The CPIC can be used with many swept liner geometries, and tailored to the desired size and shape required.

The jetting trajectory of this SHP liner device can be aimed other than parallel to the symmetrical axis of the device just by a changing the angle of attack of the detonation wave relative to the pole axis of the liner. This is done by changing the diameter and angle of the CPIC initiation of the HE billet so the detonation front engages the liner surface at either a larger or smaller diameter than the collapse axis and tangentially to the liner curvature.

To produce a straight axisymmetric hollow cylindrical jet about the symmetrical axis of the SHP liner device it is necessary to balance the explosive gas pressures and the inner and outer liner wall masses. The liner wall masses can be balanced by adjusting the wall thickness on either side of the pole at the collapse axis of the liner, these liner wall masses differ due to large volume increase as the diameter of the liner

wall increases. The HE mass also increases greatly with a diameter increase and needs to be balance correctly to the given liner mass. Adequate charge to mass ratios of explosive to liner as per Gurney equations should be adhered to as close as the application size restrictions will allow to prevent under-driving or overdriving the liner. The ideal charge to mass ratio can be tricky to obtain for a SHP liner device especially as the device becomes smaller (i.e., a 5 inch SHP liner device has more space or volume between the symmetrical axis and the collapse axis for HE mass balancing than a 2 inch SHP).

As an example of the difference in a conventional shaped charge verses the SHP liner device, the average 2 inch diameter premium oil well perforator shaped charge producing a 35 inch deep tapered hole with a 0.75 inch entrance diameter in a target removes 19.68 cubic inches of material volume. In comparison a 2 inch SHP liner device producing 6 inches of penetration and a 3 inch throughout hole diameter removes 42 cubic inches of target material. The potential for the SHP liner device to produce a 6 inch diameter non-tapered hole with 12 inches or more in penetration depth is there and in time will be developed. Oil and gas well completions and military users will benefit greatly from the use of SHP liner devices which is the goal of this shaped charge concept and development.

To initiate a swept profile shaped charge the HE billet detonation should be initiated by a simultaneous ring detonation from a Circular Precision Initiation Coupler (CPIC). The CPIC initiates detonation of the HE billet in a circular pattern at the aft end of the HE billet and at the exact diameter of the pole of the swept liner profile. The precision of the circular simultaneous initiation of the HE billet is accomplished by the use of a novel Circular Precision Initiation Coupler (CPIC). The CPIC initiation system is a single point to ring or peripheral initiation and is mated to the aft end of the HE billet and centered by the outer body so as to align the CPIC output with the pole axis of the liner. As the detonation wave reaches the intersection of the collapse axis and pole of the liner the enormous detonation pressures cause the pole material of the liner to accelerate forward and the inner and outer walls to elongate along the collapse axis forming the walls of the stretching hollow cylindrical jet. This CPIC uses a single point initiation to create a simultaneous peripheral detonation of the HE billet that collapses and drives the SHP liner into a high speed stretching hollow cylindrical projectile, or more commonly called a jet in the industry. The CPIC can be used with many swept liner geometries, and tailored to the desired size and shape required.

The jetting trajectory of this SHP liner device can be aimed other than parallel to the symmetrical axis of the device just by a changing the angle of attack of the detonation wave relative to the pole axis of the liner. This is done by changing the diameter and angle of the CPIC initiation of the HE billet so the detonation front engages the liner surface at either a larger or smaller diameter than the collapse axis and tangentially to the liner curvature.

Detonation shock wave control is very important to form stable jetting from shaped charges. Reflected shock waves can negatively affect jet formation and the overall performance of the shape charge. The SHP lined device in this embodiment has various features incorporating irregular shaped solids, in the center through hole of the liner and inner body, these shaped solids can be made from low sound speed material such as high density foam, powdered metals and combinations thereof. Since the smaller devices in this SHP liner device offers little room in the center hole in the HE billet, measures must be taken to break up, absorb and attenuate the shock from HE detonation in this region for sufficient time for the jet to form.

In order to take advantage of the penetrating power of a shaped charge to produce a full caliber hole, it is necessary to concentrate the energy of the jetting material in a different pattern than that of a conventional shaped charge, such as spreading the energy into a large diameter circle, thus the need for a Swept hemispherical profile design.

Herein disclosed is an axisymmetric circular linear shaped charge device. The shaped charge device has a liner configured in a partial toroid with a longitudinal axis intersecting an aperture located near the center of the partial toroid. The partial toroid being open-ended on a plane that intersects the longitudinal axis in a perpendicular manner toward a front end of the shaped charge device. The liner having a hollow hemispherical cross-section extending toward a closed end of the partial toroid as defined by a longitudinal plane that is aligned on the longitudinal axis and a pole of the hemispherical cross-section at a closed end of the partial toroid that extends toward a rear end of the shaped charge device. The liner having an outer surface and an inner surface with the inner surface exposed toward the open end of the front end of the shaped charge device and the liner producing an explosive hollow cylindrical jet stream directed toward the front of the shaped charge device upon detonation of the shaped charge device.

A billet of high explosive material having a front end and a rear end located behind and proximate to the outer surface of the liner and configured as a toroid with an internal aperture located proximate to the aperture of the liner. The billet producing a high explosive detonation effect applied to the liner to produce the hollow cylindrical jet stream. A coupler located in a rear portion of the shaped charge device and coupled to the rear end of the billet and the coupler producing a detonation wave initiating the high explosive detonation effect of the billet.

A body located around the outer surface of the billet and extending longitudinally the length of the billet. The body having a front end secured to the liner and a rear end secured to the coupler. An attenuator located proximate to the aperture in the billet that dampens a detonation wave. A center body located proximate to the aperture of the liner and rearward of the billet toward the rear portion of the shaped charge device.

Herein disclosed is a method of producing an axisymmetric cylindrical jet stream from a circular linear shaped charge device by providing a liner configured in a partial toroid with a longitudinal axis intersecting an aperture located near the center of the partial toroid. The partial toroid being open-ended on a plane that intersects the longitudinal axis in a perpendicular manner toward a front end of the shaped charge device. The liner having a hollow hemispherical cross-section extending toward a closed end of the partial toroid as defined by a longitudinal plane that is aligned on the longitudinal axis and a pole of the hemispherical cross-section at a closed end of the partial toroid that extends toward a rear end of the shaped charge device. The liner having an outer surface and an inner surface with the inner surface exposed toward the open end of the front end of the shaped charge device.

Positioning a billet of high explosive material behind and proximate to the outer surface of the liner and proximate to the aperture of the liner. The billet producing a high explosive detonation effect applied to the liner to produce the hollow cylindrical jet stream. Positioning a coupler at a rear portion of the shaped charge device in contact with the rear of the billet. The coupler producing a detonation wave and initiating the high explosive detonation effect of the billet.

Surrounding the shaped charge device with a body around the outer diameter of the billet and extending longitudinally the length of the billet. Producing an explosive hollow cylindrical

jet stream with the liner that is directed toward the front of the shaped charge device upon detonation of the shaped charge device.

Additionally you can provide an attenuator proximate to the aperture in the billet that dampens a detonation wave. Positioning a center body proximate to the aperture of the liner and rearward of the billet toward the rear portion of the shaped charge device.

The swept hemispherical shaped charge (SHSC) **100**, having an aft area and a fore area, is shown in FIG. 1 and consists of a swept hemispherical profile (SHP) liner **105**, a body **110**, a high explosive (HE) billet **115** which is a mass of high explosive, a Circular Precision Initiation Coupler (CPIC), an explosive shock attenuator (ESA) **140**, a center body **145**, an inner retaining ring **150**, and an outer retaining ring **155**. All components of device **100** share a common symmetrical axis **185**.

The SHP liner **105**, located about the fore area of the SHSC, is the working material of the shaped charge and will be optimized in thickness, profile and material to produce the desired effects on the target material. Preferably the liner uses a copper material, but liners may be made from most any metal, ceramic, powdered metals, tungsten, silver, copper or combination of many materials.

The SHP liner **105**, as singularly shown in FIG. 1A, has an inside wall **165**, an outside wall **170**, a pole **160** an outer base end **180**, an inner base end **181**, an outer semicircle surface **178**, and an inner semicircle surface **175**. Outer semicircle **178** and inner semicircle **175** can be concentric to each other or offset centers to tailor the thickness of the inside wall **165** and outside wall **170**. Stable jetting can be achieved if the SHP liner **105** wall mass on either side of the pole **160** at the collapse axis **190** is balanced correctly. The mass of a constant wall thickness Liner will increase greatly from the inside diameter (ID) closest to the symmetrical axis **185** to the outside diameter (OD) because of the large volume increase as the diameter of the liner wall increases from the ID to the OD. This can be solved by offsetting the centers of outer semicircle **178** to inner semicircle **175** making the inside wall **165** thicker than the outside wall **170** to achieve equal liner wall mass on both sides of collapse axis **190**.

Offset semicircle centers will make the thickness of inside wall **165** gradually increase from the pole **160** to the inner base end **181**, and the thickness of outside wall **170** gradually decrease from pole **160** to the outer base end **180**. The wall thickness is varied in this way to balance the explosive charge to SHP liner **105** mass ratios, which also balances the momentum of the collapse and stretching of the SHP liner **105** walls.

For example, with a 5 inch diameter liner of offset semicircle centers, the inside wall **165** needs to be between 1-3 mm at the pole **160** and taper toward the inner base end **181** to between 2-5 mm. The outside wall **170** must taper the reverse direction from between 1.5-3 mm at the pole **160** and tapering down to between 1-2.5 mm at the outer base end **180**. These dimensions will be refined with numerical code and experiment to give the most tailored jet to address the specific target material. Jet velocities can vary from 4 to 10 km/s depending on the liner material, wall thickness and other geometries. Other thickness profiles of the liner can be utilized to balance liner wall momentums (i.e., making both the inside wall **165** and outside wall **170** into multiple arcs to accomplish the desired profile thickness that will produce the best projectile performance).

The HE billet **115** provides the energy to collapse the SHP liner **105**, increases the ductility, and focuses the flowing material causing it to form a long hollow cylindrical stretching very high velocity projectile commonly called a jet. The

body **110** provides an outer mounting surface for SHP liner **105** which is held to body **110** by outer retaining ring **155**. Body **110** also serves as a containment vessel to protect and hold the shape of the delicate HE billet **115** from damage or impact. Body **110** can provide tamping for HE billet **115** depending on body **110** thickness and material density.

The HE billet **115** in its most basic form is a right circular cylinder having a through hole at its center leaving a wall thickness, or distance from the inside diameter to the outside diameter of the HE billet, greater than the annulus width (AW) between the inside and outside diameters of the liner. The HE billet **115** is of sufficient length to provide adequate head height of HE aft of the liner outer semicircle surface **178** so there is sufficient HE to drive the liner **105** in the desired fashion. The fore end of the HE billet **115** has a concentric swept concavity matching the outer semicircle surface **178** of the liner, which is a convex surface, in size and contour. The thickness of the HE billet **115** being larger than the AW provides for super caliber explosive all the way to the equator of the half torus or circular hollow trough. This makes for higher jet velocities, more jet mass, longer jet and better penetration performance. The liner **105** is inserted snugly into the concavity of the HE billet **115**, making a liner/HE sub-assembly of the device. The SHSC device can use cast, pressed, extruded or even hand packed HE from any high quality explosive.

The wall thickness of the HE billet **115** can range from about 0-25% larger than the AW of the SHP liner **105** and still produce a proper jet. If the wall thickness of the liner and the amount of HE used are not correctly matched for the application it will result in an under driven or over driven liner, neither event will produce proper jetting. Adequate charge to mass ratios of HE to liner as per Gurney equations should be adhered to as close as the application size restrictions will allow to prevent underdriving or overdriving the liner.

To initiate a swept profile shaped charge, the HE billet **115** detonation should be initiated by a simultaneous ring detonation from a Circular Precision Initiation Coupler (CPIC). The CPIC, located in the aft area of the SHSC, consists of a CPIC HE **120**, charge cover **125**, detonator **130**, and CPIC HE cover **135**. Detonator **130**, located about the aft of the CPIC, provides the initial detonation impulse to the shallow cup shaped CPIC HE **120**. Charge cover **125** provides a mounting cavity **131** for detonator **130** and CPIC HE **120**, and provides the critical alignment of detonator **130** with CPIC HE **120** on the symmetrical axis **185**. Charge cover **125** also provides the critical alignment of CPIC HE **120** with HE billet **115**, this alignment allows for a precise ring initiation of HE billet **115**. Charge cover **125** also serves to cover and protect HE billet **115** and maintains intimate contact of CPIC HE **120** with the HE billet **115**. The CPIC function is to transform a single point initiation from detonator **130** into a ring detonation of the CPIC HE **120** that will ring initiate the aft end of the HE billet **115** which is precisely aligned with the collapse axis **190** and pole of SCP liner **105**.

The CPIC initiates detonation of the HE billet **115** in a circular pattern at the aft end and at the exact diameter of the pole of the SHP liner **105**. The precision of the circular simultaneous initiation of the HE billet **115** is accomplished by the use of a novel Circular Precision Initiation Coupler (CPIC). The CPIC initiation system is a single point to ring or peripheral initiation and is mated to the aft end of the HE billet **115** and centered by the outer body **110** so as to align the CPIC output with the pole axis of the liner **105**. As the detonation wave reaches the intersection of the collapse axis **190** and pole **160** of the liner **105**, the enormous detonation pressures cause the pole material of the liner **105** to accelerate forward

and the inner **165** and outer **170** walls to elongate along the collapse axis **190** forming the walls of the stretching hollow cylindrical jet. This CPIC uses a single point initiation to create a simultaneous peripheral detonation of the HE billet **115** that collapses and drives the SHP liner **105** into a high speed stretching hollow cylindrical projectile, or more commonly called a jet in the industry. The CPIC can be used with many swept liner geometries, and tailored to the desired size and shape required.

The jetting trajectory of this SHP liner **105** can be aimed other than parallel to the symmetrical axis of the device just by a changing the angle of attack of the detonation wave relative to the pole axis of the liner **105**. This is done by changing the diameter and angle of the CPIC initiation of the HE billet **115** so the detonation front engages the liner outer semicircle surface **178** at either a larger or smaller diameter than the collapse axis **190** and tangentially to the liner curvature.

To produce a straight axisymmetric hollow cylindrical jet about the symmetrical axis **185** of the SHSC device, it is necessary to balance the explosive gas pressures and the inner **165** and outer **170** liner wall masses. The liner wall masses can be balanced by adjusting the wall thickness on either side of the pole **160** at the collapse axis **190** of the liner **105**, these liner wall masses differ due to large volume increase as the diameter of the liner wall increases. The HE mass also increases greatly with a diameter increase and needs to be balance correctly to the given liner mass. Adequate charge to mass ratios of explosive to liner as per Gurney equations should be adhered to as close as the application size restrictions will allow to prevent underdriving or overdriving the liner. The ideal charge to mass ratio can be tricky to obtain for a SHP liner device especially as the device becomes smaller (i.e., a 5 inch SHP liner device has more space or volume between the symmetrical axis and the collapse axis for HE mass balancing than a 2 inch SHP).

The ESA **140** is a shock attenuator made from a low sound velocity material and serves as a detonation wave dampener. Center body **145** supports the inner diameter of HE billet **115**, provides space for ESA **140**, a path for escaping detonation gases, and other devices (i.e., secondary projectile forming devices). Center body **145** provides an inner mounting surface for SCP liner **105** and aligns it with symmetrical axis **185**. SCP liner **105** is held to center body **145** by inner retaining ring **150**. Device **100** is capable of producing a hollow cylindrical jet from the SCP liner **105** that will produce a full charge diameter hole in the target.

The center body **145** is encompassed by the explosive charge or main high explosive (HE) billet and can be solid or hollow. The hollow center body **145** being an essential part of the swept profile design could contain shock attenuation materials used to dampen, reflect, and absorb shock waves that would have a detrimental effect on the formation of a stable jet. The hollow center body **145** space can also be used to contain a center projectile producing device or for adjusting HE billet quantity driving the inside wall of the liner, in addition the space can be used to relieve pressure from expanding gasses from the detonation of the HE.

Detonation shock wave control is very important to form stable jetting from shaped charges. Reflected shock waves can negatively affect jet formation and the overall performance of the shape charge. The SHP liner **105** design in this embodiment has various features incorporating irregular shaped solids, in the hollow center body **145**. These shaped solids can be made from low sound speed material such as high density foam, powdered metals and combinations thereof. Since the smaller SHSC devices offer little room in

the center body **145**, measures must be taken to break up, absorb and attenuate the shock from HE detonation in this region for sufficient time for the jet to form.

In order to take advantage of the penetrating power of a SHP ACLSC to produce a full caliber hole, it is necessary to concentrate the energy of the jetting material in a different pattern than that of a conventional shaped charge, such as spreading the energy into a large diameter circle, thus the need for a swept hemispherical profile design. Timing and momentum balancing of the collapsing liner material is critical for jet creation and stability. If the swept liner wall thickness and the amount of explosive used are not correctly matched for the application it will result in an under driven or over driven liner, neither event will produce proper jetting.

FIG. 1A shows the SHP liner **105** that is used in device **100** of FIG. 1. The SHP liner **105** consists of an outer base end **180**, inside wall **165**, pole **160**, inner base end **181**, outside wall **170**, axis of symmetry **185**, collapse axis **190**, an outer semicircle **178** and an inner semicircle **175**. Collapse axis **190** is shown parallel to the axis of symmetry **185**, but can be almost any angle relative to the axis of symmetry **185** that would represent a converging or diverging jet trajectory formed by the focusing of the shaped explosive on the SHP liner **105**. The SHP liner **105** is a thin walled half hemispherical profile, swept or revolved about a central symmetrical axis **185**. The swept profile having an inside and outside diameter, a radius depth to inner semicircle **175** and outer semicircle **178** along the collapse axis **190**, and when revolved about its symmetrical axis **185** it forms a hollow circular trough with a semicircular concavity between the inner and outer diameters. There is a wall thickness to this trough that is proportional to the outside diameter minus the inside diameter of the liner.

Outer semicircle **178** and inner semicircle **175** can be concentric to each other or offset centers to tailor the thickness of the inside wall **165** and outside wall **170**. Stable jetting can be achieved if the SHP liner **105** wall mass on either side of the pole **160** at the collapse axis **190** is balanced correctly. The mass of a constant wall thickness Liner will increase greatly from the inside diameter (ID) closest to the symmetrical axis **185** to the outside diameter (OD) because of the large volume increase as the diameter of the liner wall increases from the ID to the OD. This can be solved by offsetting the centers of outer semicircle **178** to inner semicircle **175** making the inside wall **165** thicker than the outside wall **170** to achieve equal liner wall mass above and below the collapse axis **190**.

Offset semicircle centers will make the thickness of inside wall **165** gradually increase from the pole **160** to the inner base end **181**, and the thickness of outside wall **170** gradually decrease from pole **160** to the outer base end **180**. The wall thickness is varied in this way to balance the explosive charge to SHP liner **105** mass ratios, which also balances the momentum of the collapse and stretching of the SHP liner **105** walls. Liner wall momentum balancing will insure that inside wall **165** and outside wall **170** will stretch to approximately the same length and meet at the collapse axis **190** in concert to produce stable jetting. SHP liners are typical easier to balance than swept conical liners and produce more massive jets. Balancing the liner wall momentums should not be held only to the offset method previously described. Other thickness profiles of the liner can be utilized to balance liner wall momentums, i.e., multiple arcs making both the inside wall **165** and outside wall **170** could also be used to accomplish the desired profile thickness that will produce the best projectile performance.

For example, with a 5 inch diameter liner of offset semicircle centers, the inside wall **165** needs to be between 1-3 mm

at the pole **160** and taper toward the inner base end **181** to between 2-5 mm. The outside wall **170** must taper the reverse direction from between 1.5-3 mm at the pole **160** and tapering down to between 1-2.5 mm at the outer base end **180**. These dimensions will be refined with numerical code and experiment to give the most tailored jet to address the specific target material. Jet velocities can vary from 4 to 10 km/s depending on the liner material, wall thickness and other geometries. Other thickness profiles of the liner can be utilized to balance liner wall momentums (i.e., making both the inside wall **165** and outside wall **170** into multiple arcs to accomplish the desired profile thickness that will produce the best projectile performance).

FIG. 1B is a cross-sectional view of a typical hollow cylindrical projectile (HCP) **106** produced by a SHP liner device. The HCP **106** consists of a jet **194**, jet tail **192**, jet tip **191**, projection axis **195**, and symmetrical axis **185**. Jet **194** angle of projection, thickness, length and inside diameter can vary depending on the design of the SHP liner device. The Projection axis **195** is shown parallel to symmetrical axis **185** but could be almost any angle either converging or diverging depending on the SHP liner device design and intended use.

This depiction of HCP **106** is at a finite time after the detonation of a SHSC. The HCP **106** at an earlier time frame after detonation would show the jet **194** shorter in length. At a later time frame, jet **194** would become longer and thinner because of the ductile stretching of the HCP material. The projection axis **195** is shown parallel to symmetrical axis **185** but could be almost any angle either converging or diverging depending on the SHSC design and intended use.

The SHSC is balancing the momentums of the collapsing inner **165** and outer **170** liner walls producing a stable projectile that will remove the full diameter of target material creating a hole without leaving behind a center core. If the momentums of a SHSC are not matched correctly, the jet will not follow the desired trajectory, be of insufficient mass for desired target penetration or not form at all.

The invention claimed is:

1. An axisymmetric circular linear shaped charge device, comprising:

a liner configured in a partial toroid with a longitudinal axis extending lengthwise and intersecting an aperture located near the center of said partial toroid, said partial toroid being open-ended on a plane that intersects said longitudinal axis in a perpendicular manner toward a front end of the shaped charge device, said liner having a hollow hemispherical cross-section extending toward a closed end of the partial toroid as defined by a longitudinal plane that is aligned on said longitudinal axis and a pole of said hemispherical cross-section at a closed end of the partial toroid that extends toward a rear end of said shaped charge device, said liner having an outer surface and an inner surface, said inner surface exposed toward the open end of the front end of the shaped charge device and said liner producing an explosive hollow cylindrical jet stream directed toward said front of said shaped charge device substantially parallel to said longitudinal axis upon detonation of the shaped charge device;

a billet of high explosive material having a front end and a rear end located behind and proximate to the outer surface of said liner, said billet configured as a toroid with an internal aperture located proximate to the aperture of the liner, and said billet producing a high explosive detonation effect applied to said liner to produce said hollow cylindrical jet stream;

a coupler located in a rear portion of the shaped charge device, said coupler coupled to the rear end of the billet

13

and said coupler producing a detonation wave initiating the high explosive detonation effect of the billet; and a body located around the outer surface of the billet and extending longitudinally the length of the billet, said body having a front end secured to said liner and, said body having a rear end secured to the coupler.

2. The shaped charge of claim 1, wherein the coupler initiates a high explosive detonation effect on the billet to direct the trajectory of said hollow cylindrical jet stream toward the longitudinal axis of the shaped charge device.

3. The shaped charge of claim 1, further comprising: an attenuator located proximate to the aperture in the billet, said attenuator dampening a detonation wave.

4. The shaped charge of claim 1, wherein said coupler initiates a ring initiation at the rear end of the billet to produce the detonation wave and initiate the high explosive detonation effect of the billet.

5. The shaped charge of claim 1, wherein the coupler provides the critical alignment of the detonator with the coupler high explosive on the longitudinal axis of the shaped charge and provides the critical alignment of the coupler high explosive with the billet which to allow for a precise ring initiation of the billet.

6. The shaped charge of claim 1, further comprising: a center body located proximate to the aperture of said liner and rearward of the billet toward the rear portion of the shaped charge device.

7. The shaped charge of claim 6, wherein the center body is hollow and provides a space for shock attenuation materials used to dampen shock waves.

8. The shaped charge of claim 7, wherein the space within the hollow center body can be used to contain a center projectile producing device.

9. An axisymmetric circular linear shaped charge device, comprising:

a liner configured in a partial toroid with a longitudinal axis extending lengthwise and intersecting an aperture located near the center of said partial toroid, said partial toroid being open-ended on a plane that intersects said longitudinal axis in a perpendicular manner toward a front end of the shaped charge device, said liner having a hollow hemispherical cross-section extending toward a closed end of the partial toroid as defined by a longitudinal plane that is aligned on said longitudinal axis and a pole of said hemispherical cross-section at a closed end of the partial toroid that extends toward a rear end of said shaped charge device, said liner having an outer surface and an inner surface, said inner surface exposed toward the open end of the front end of the shaped charge device and said liner producing an explosive hollow cylindrical jet stream directed toward said front of said shaped charge device substantially parallel to said longitudinal axis upon detonation of the shaped charge device;

a billet of high explosive material having a front end and a rear end located behind and proximate to the outer surface of said liner, said billet configured as a toroid with an internal aperture located proximate to the aperture of the liner, and said billet producing a high explosive detonation effect applied to said liner to produce said hollow cylindrical jet stream;

a coupler located in a rear portion of the shaped charge device, said coupler coupled to the rear end of the billet and said coupler producing a detonation wave initiating the high explosive detonation effect of the billet;

a body located around the outer surface of the billet and extending longitudinally the length of the billet, said

14

body having a front end secured to said liner and, said body having a rear end secured to the coupler; and said shaped charge device producing an explosive hollow cylindrical jet upon detonation of said shaped charge device, said hollow cylindrical jet forming a hole in a target material that is wider than the outer diameter of the shaped charge device.

10. The shaped charge of claim 9, wherein the coupler initiates a high explosive detonation effect on the billet to direct the trajectory of said hollow cylindrical jet stream toward the longitudinal axis of the shaped charge device.

11. The shaped charge of claim 9, further comprising: an attenuator located proximate to the aperture in the billet, said attenuator dampening a detonation wave.

12. The shaped charge of claim 9, wherein said coupler initiates a ring initiation at the rear end of the billet to produce the detonation wave and initiate the high explosive detonation effect of the billet.

13. The shaped charge of claim 9, wherein the coupler provides the critical alignment of the detonator with the coupler high explosive on the longitudinal axis of the shaped charge and provides the critical alignment of the coupler high explosive with the billet which to allow for a precise ring initiation of the billet.

14. The shaped charge of claim 9, further comprising: a center body located proximate to the aperture of said liner and rearward of the billet toward the rear portion of the shaped charge device.

15. The shaped charge of claim 14, wherein the center body is hollow and provides a space for shock attenuation materials used to dampen shock waves.

16. The shaped charge of claim 15, wherein the space within the hollow center body can be used to contain a center projectile producing device.

17. A method of producing an axisymmetric cylindrical jet stream from a circular linear shaped charge device, comprising the steps of:

providing a liner configured in a partial toroid with a longitudinal axis extending lengthwise and intersecting an aperture located near the center of said partial toroid, said partial toroid being open-ended on a plane that intersects said longitudinal axis in a perpendicular manner toward a front end of the shaped charge device, said liner having a hollow hemispherical cross-section extending toward a closed end of the partial toroid as defined by a longitudinal plane that is aligned on said longitudinal axis and a pole of said hemispherical cross-section at a closed end of the partial toroid that extends toward a rear end of said shaped charge device, said liner having an outer surface and an inner surface, said inner surface exposed toward the open end of the front end of the shaped charge device;

positioning a billet of high explosive material behind and proximate to the outer surface of said liner, said billet being proximate to the aperture of the liner, and said billet producing a high explosive detonation effect applied to said liner;

positioning a coupler at a rear portion of the shaped charge device in contact with the rear of the billet, said coupler producing a detonation wave and initiating the high explosive detonation effect of the billet;

surrounding the shaped charge device with a body around the outer diameter of the billet and extending longitudinally the length of the billet; and

producing an explosive hollow cylindrical jet stream with the liner that is directed toward said front of said shaped

15

charge device substantially parallel to said longitudinal axis upon detonation of the shaped charge device.

18. The method of claim 17, wherein the coupler initiates a high explosive detonation effect on the billet to direct the trajectory of said hollow cylindrical jet stream toward the longitudinal axis of the shaped charge device.

19. The method of claim 17, further comprising the step of: providing an attenuator proximate to the aperture in the billet, said attenuator dampening a detonation wave.

20. The method of claim 17, wherein said coupler initiates a ring initiation at the rear end of the billet to produce the detonation wave and initiate the high explosive detonation effect of the billet.

21. The method of claim 17, wherein the coupler provides the critical alignment of the detonator with the coupler high explosive on the longitudinal axis of the shaped charge and provides the critical alignment of the coupler high explosive with the billet which to allow for a precise ring initiation of the billet.

16

22. The method of claim 17, further comprising the step of: positioning a center body proximate to the aperture of said liner and rearward of the billet toward the rear portion of the shaped charge device.

23. The method of claim 22, wherein the center body is hollow and provides a space for shock attenuation materials used to dampen shock waves.

24. The method of claim 23, wherein the space within the hollow center body can be used to contain a center projectile producing device.

25. The method of claim 17, further comprising the step of: producing an explosive hollow cylindrical jet upon detonation of said shaped charge device, said hollow cylindrical jet forming a hole in a target material that is wider than the outer diameter of the shaped charge device.

* * * * *